

**VERDERMAG**  
*Global PC 100L/M*

*Maintenance Manual*

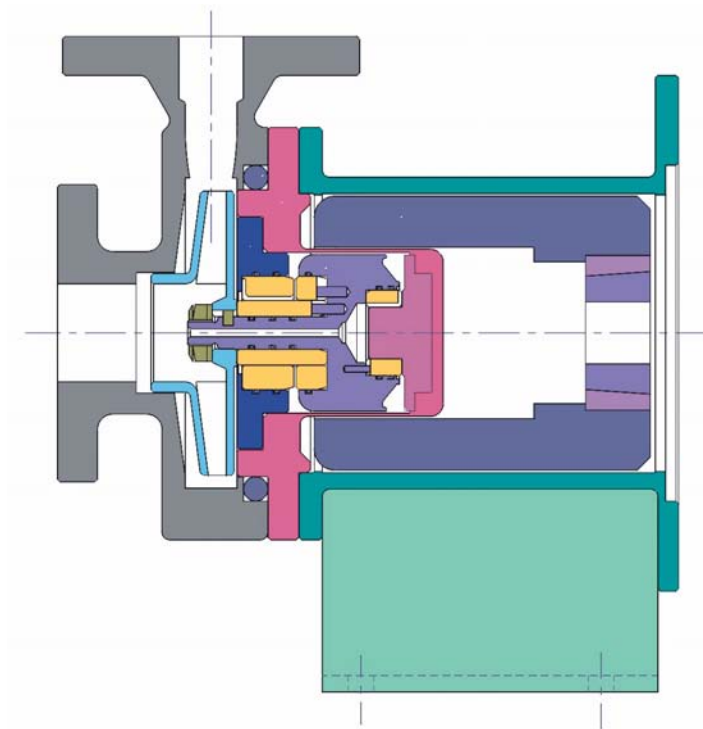

***THIS DOCUMENT SHOULD STAY WITH THE PUMP  
UNIT AT ALL TIMES!***

***To be read in conjunction with Installation And Operating Manual***

## Index

### **1.0 DOCUMENTATION**

1.1 [Type Hydrostatic Test Certificate](#)

1.2 [Type Performance Certificate](#)

### **2.0 MAINTENANCE**

2.1 [Assembly Instructions](#)

2.2 [On Site Disassembly Instructions](#)

2.3 [Tag Plate Detail](#)

2.4 [Standard Sectional Assembly Drawing](#)

2.5 [Component List](#)

### **3.0 DIMENSIONS**

3.1 [Tabulated Drawing](#)

3.2 [Flange Standards](#)

3.3 [Universal Flange Dimensions](#)

3.4 [PN1.6 Flange Dimensions](#)

3.5 [ANSI.150 Flange Dimensions](#)

3.6 [ANSI.300 Flange Dimensions](#)

## ***1.0 DOCUMENTATION***

### ***1.1 Type Hydrostatic Test Certificate***

#### ***Global Style 1 type PC***

We hereby certify that the above specified equipment supplied by Verder has been hydrostatically tested in accordance with the current issue of procedure reference VMP.005 and is satisfactory in all respects thereof:-

Test Pressure: **24 barG**

Test Temperature: **20 °C**

### ***1.2 Type Performance Test Certificate***

***(For units supplied with drive motor fitted by Verder Ltd in the UK)***

#### ***Global type PC 100L/M***

We hereby certify that the above specified equipment supplied by Verder has been tested in accordance with the current issue of procedure reference VMP.007 and meets the following requirements:-

- Standard relevant performance curve at trim diameter detailed on tag plate.
- Duty flowrate and differential pressure detailed within purchase order (where stated).

## 2.1 Assembly Instructions

### Global PC 100L/M

The pump unit is assembled to the following procedure in accordance with the standard build specification (see relevant section).

#### Step 1 Cartridge Assembly

##### Items required

Reference	Description
3	Bearing holder
4	Casing joint
5.1	Backplate assembly
5.2	End cap spigot
6	Pump shaft assembly
10.1	Front bearing assembly
10.2	Front bearing O-ring kit
11.1	Rear bearing assembly
11.2	Rear bearing O-ring kit (Silicon Carbide rear bearings only)

Front bearing o-ring kits are separated into the two common size o-rings. The smallest set is fitted into the external grooves in the front of the pump shaft. The largest set is fitted into the internal groove in the front of the pump shaft and the rear of the bearing holder.

**Note:** Care should be taken not to damage any o-rings. Any o-rings damaged during fitting should be replaced prior to continuation of assembly.

Bearing lubricant is applied to all surfaces machined with o-ring grooves.

Front and rear bearings components can now be fitted to onto/into the relevant components as follows:

Rear bearing bush -> Pumpshaft (rear)  
 Front bearing thrust ring -> Pumpshaft (front)  
 Front bearing sleeve -> Pumpshaft  
 Front bearing bush -> Bearing holder



#### **Warning.**

Extreme care should be taken when handling damaged bearings. Silicon carbide is a very hard and brittle material. The edges of any fractures or breaks will be very sharp.

***(Standard Fluoroscint rear bearing only)***



The single rear bearing component should be pushed into the rear of the pumpshaft. Care should be taken to ensure the hole in the bearing and the anti-rotation pin in the pumpshaft are correctly aligned. Please note that no o-rings are required for support of the bearing.

***(Silicon Carbide rear bearings only)***

Rear bearing o-ring kits are separated into the two common size o-rings. The smallest set is fitted into the external grooves in the rear shaft (see picture) on the end cap spigot. The largest set is fitted into the internal groove in the rear of the end cap spigot and the rear of the pump shaft.

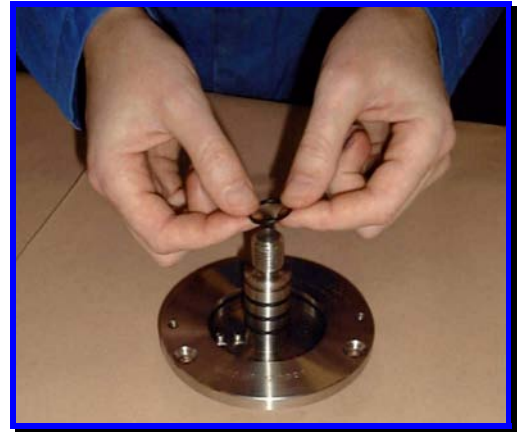

Bearing lubricant is applied to all surfaces machined with o-ring grooves.

Front and rear bearings components can now be fitted to onto/into the relevant components as follows:

- Rear bearing thrust ring -> Endcap spigot
- Rear bearing sleeve -> End cap spigot shaft  
(see picture)
- Rear bearing bush -> Pumpshaft (rear)

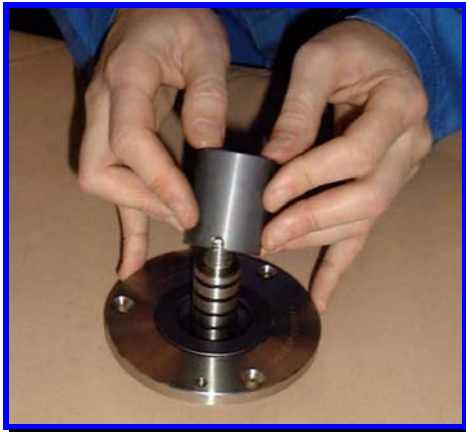

**Note:** Care should be taken not to damage any bearing components particularly when passing over anti-rotation pins. Any bearings damaged during fitting should be replaced prior to continuation of assembly.



**Warning.**

Extreme care should be taken when handling damaged bearings. Silicon carbide is a very hard and brittle material. The edges of any fractures or breaks will be very sharp.



The supplied rear bearing washer and locknut is fitted with fastener anti-seize to the containment tube shaft once rear bearing thrust ring and sleeve are in place. The locknut should be tightened to a torque of 30Nm (21.6 ft.lb).

**(All units)**

Position the backplate assembly on a flat surface with the flange upwards.

Lower the end cap spigot to the bottom of the containment tube and secure using the supplied fasteners ensuring that the top face is parallel to the containment tube flange.

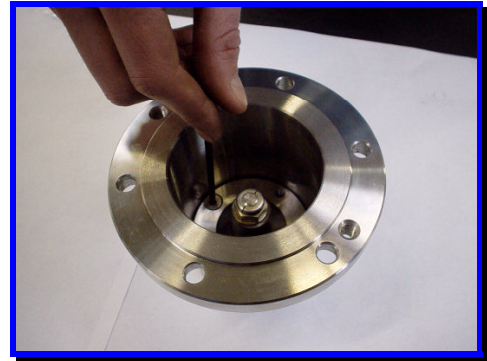

**Tip.**

To maintain concentricity of components within the pump unit it is necessary to have an interference fit between the end cap spigot and the containment tube assembly.

Therefore the fitting of the end cap spigot is made easier if the containment tube is warm. Running the containment tube under a warm tap will cause sufficient expansion of the material to enable the end cap to be pushed down.

**Note:** Ensure that the pumpshaft is free from particles collected by the magnetised area.

The pump shaft can now be carefully lowered into the backplate assembly. To aid grip on the pumpshaft it may be useful to hand tighten the locknut onto the pumpshaft before lowering into the backplate assembly.

The bearing holder is fitted to the backplate assembly over the protruding pump shaft and secured using the supplied screws with fastener anti-seize. The screws should be tightened to a torque of 20Nm (14.4 ft.lb).

**Step 2**  
**Outer Magnet Assembly**

**Items required**

Reference	Description
7.1	Outer magnet assembly
7.2	Taper lock adaptor
7.3	Taper lock bush
8.1	Pedestal
8.2	Pedestal adaptor flange (where required)

If required the pedestal adaptor flange should be fitted to the pedestal.

The taper lock bush and adaptor are pushed into the outer magnet. The supplied grub screws are loosely fitted to enable movement of the bush within the adaptor.

The motor is placed on its cowl with the motor shaft facing upwards. The pedestal is fitted onto the motor flange and secured using the supplied fasteners with fastener anti-seize.



The outer magnet complete with taper lock adaptor and bush are then lowered onto the motor shaft. The outer magnet setting distance of 6mm, taken from the highest point on the magnet assembly to the highest point on the pedestal (see picture), should now be checked.

Any adjustments in outer magnet height by lifting or lowering the magnet assembly. When the setting distance is correct the screws are tightened. The magnet height is then to be re-checked.

*Note: The action of tightening the grub screws affects a 1-2mm increase in the setting distance. Account should be taken of this when setting the rotor.*

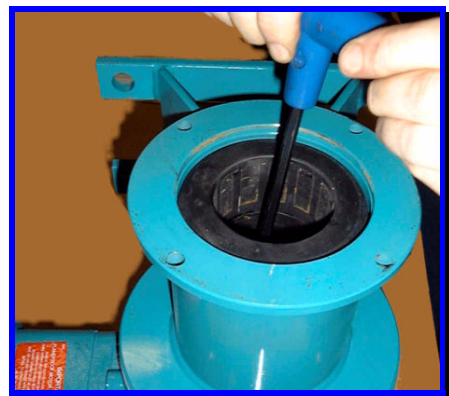

**Step 3**  
**Pump 'wet end' Assembly**

**Items required**

Reference	Description
-	Cartridge assembly
-	Outer magnet / pedestal/motor (when fitted) assembly
1	Casing
2	Impeller

**Note:**

*Verder advise that where an impeller trim is required on a fabricated impeller, the unit is returned to our works in Leeds (UK). Trimming of a fabricated impeller may disturb the welding of the vanes. The impeller would therefore require re welding ensuring it was fit for purpose.*

The impeller drive pin is fitted into the hole of the pump shaft.



The impeller is fitted to the shaft and secured with the impeller locknut and washer using fastener anti-seize. The locknut should be tightened to a torque of 40Nm (28.8 ft.lb).

The casing is placed on a flat surface (suction flange down).

The casing joint is then secured into the casing and the backplate assembly lowered onto the casing and secured with the supplied fasteners using fastener anti-seize. The screws should be tightened to a torque of 40Nm (28.8 ft.lb).

**Note:**

*Care should be taken when assembling the cartridge assembly to the casing to ensure that fasteners are fitted into the six countersunk holes only at this stage. The position of the tapped holes should also be noted to ensure that when assembled these line up correctly with the corresponding holes in the pedestal.*

The casing/cartridge assembly can now be assembled to the pedestal (bareshaft unit) or the pedestal/motor assembly. The pedestal should be secured using the supplied fasteners with fastener anti-seize. The screws should be tightened to a torque of 40Nm (28.8 ft.lb).

*Note: Care should be taken when passing the containment tube into the outer magnet assembly to ensure no damage is caused to the magnets. The correct lifting apparatus should be used to aid fitting of the assemblies.*

**2.2 On Site Disassembly Instructions**

**Global PC 100L/M**

Generally disassembly should be carried out in the reverse order to the assembly instructions detailed above. However, some exceptions may apply dependant on site conditions etc.

### 2.3 Tag Plate

The tag plate will be supplied with 4 fixing studs and the model code, pump / serial number and test pressure already stamped.

<b>VERDERMAG</b>	
<b>Model</b>	
<b>Date</b>	/ /
<b>Serial No.</b>	
<b>Impeller Ø</b>	mm
<b>Weight</b>	kg
<b>Test pressure</b>	Bar
<b>Speed</b>	rpm
<b>Flow</b>	mCu/hr
<b>Head</b>	m
<b>ATEX 01/03</b>	Grp. II Cat. 2 GD c / k
<b>Temp. class</b>	
<b>Max liquid temp.</b>	
<b>PED</b>	Notified Body EC
<b>DO NOT RUN DRY</b>	
	
VERDER Ltd., Whitehouse Street, Leeds, LS10 1AD England	

See code sheet in Installation And Operating Manual

Date of construction

Serial number (required for reference)

Installed final diameter

Pump head weight

Hydrostatic test pressure

Nominal motor speed from motor tag plate

Nominal flowrate

Nominal differential head

ATEX classification (pump head only)

ATEX temperature classification

ATEX maximum allowable pump liquid temperature

\* Pressure Equipment Directive notified body EC reference number

The pump model codes are detailed in the Installation And Operating Manual.

\* This pump type falls into the list of excluded items contained within the 'Pressure Equipment Directive' 97/23/EC 29<sup>th</sup> May 1997.

**2.4 Standard Sectional Assembly Drawing**

ITEM N°	DESCRIPTION	QTY.
1	CASING	One
2	IMPELLER ASSEMBLY	(*S3)
3	BEARING HOLDER	One
4	CASING O-RING	(1-OFF *S1) (1-OFF *S2)
5.1	BACKPLATE ASSEMBLY	One
5.2	END CAP SPIGOT	(*S2)
6	PUMP SHAFT ASSEMBLY	One
7.1	OUTER ROTOR ASSEMBLY	One
7.2	OUTER ROTOR TAPER LOCK ADAPTOR	One
7.3	OUTER ROTOR TAPER LOCK BUSH	One
8.1	PEDESTAL	One
8.2	PEDESTAL ADAPTOR FLANGE (see item N° 8.1)	One
9.1	FASTENER KIT 100LIM LOCKNUT, WASHER, KEY (*S2)	One
10.1	FRONT BEARING ASSEMBLY (SIZE 2)	(*S2)
10.2	O-RING KIT (SIZE 2)	(*S2)
11	REAR BEARING (SIZE 1)	One
—	CARTRIDGE ASSEMBLY	(*S3)

RECOMMENDED SPARES:-  
 \*S1 COMMISSIONING SPARES  
 \*S2 2 YEARS OPERATIONAL SPARES  
 \*S3 HOLDING SPARES

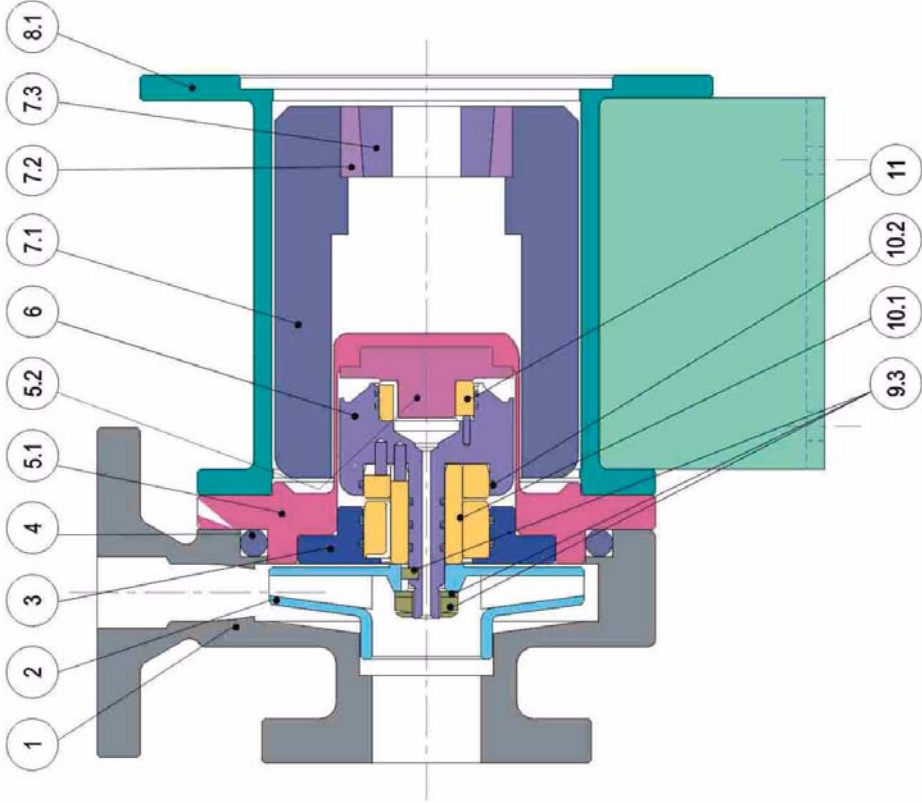

## 2.5 Component List

### PC 100L / M

Item	Part Number	Long Description	Material Specification
1	CAS.1001S	100L CASING FABRICATED STD 316LS11	STAINLESS STEEL 316S11 TO BS 1503
1	CAS.10011	100L CASING FABRICATED PN16 316LS11	STAINLESS STEEL 316S11 TO BS 1503
1	CAS.10013	100L CASING FABRICATED ANSI150LB 316LS11	STAINLESS STEEL 316S11 TO BS 1503
1	CAS.1003S	100M CASING FABRICATED STD 316LS11	STAINLESS STEEL 316S11 TO BS 1503
1	CAS.10031	100M CASING FABRICATED PN16 316LS11	STAINLESS STEEL 316S11 TO BS 1503
1	CAS.10033	100M CASING FABRICATED ANSI150LB 316LS11	STAINLESS STEEL 316S11 TO BS 1503
1	CAS.1000S	100L CASING CAST STANDARD 316C16	STAINLESS STEEL 316C16 TO BS 1504
1	CAS.10001	100L CASING CAST PN16 316C16	STAINLESS STEEL 316C16 TO BS 1504
1	CAS.10003	100L CASING CAST ANSI150LB 316C16	STAINLESS STEEL 316C16 TO BS 1504
1	CAS.1002S	100M CASING CAST STANDARD 316C16	STAINLESS STEEL 316C16 TO BS 1504
1	CAS.10021	100M CASING CAST PN16 316C16	STAINLESS STEEL 316C16 TO BS 1504
1	CAS.10023	100M CASING CAST ANSI150LB 316C16	STAINLESS STEEL 316C16 TO BS 1504
2	IMP.100L.00	IMPELLER 100L STYLE 1 B1 SIC	STAINLESS STEEL 316S11 TO BS 1503
2	IMP.100M.00	IMPELLER 100M STYLE 1 B1 SIC 316L	STAINLESS STEEL 316S11 TO BS 1503
3	BHR.100/125.00	BEARING HOLDER 100L/M & 125 1 B	STAINLESS STEEL 316S11 TO BS 1503
4	VIT.100.00	O RING CASING JOINT 100L/M VITON BS351	VITON E-60C
4	EPDM.100.00	O RING CASING JOINT 100L/M EPDM BS351	ETHYLENE PROPYLENE TERPOLYMER
4	PTFE.100.00	O RING CASING JOINT 100L/M PTFE BS351	FEP ENCAPSULATED VITON
5	BPA.100.00	BACKPLATE ASSY 100L/M B1 SIC/FL 316/C276	STAINLESS STEEL 316S11 TO BS 1503 / HASTELLOY C276 TO ASTM-SB575-95
6	PSA.B1.00	PUMP SHAFT ASSEMBLY 100L/M SIC/FL 316L	STAINLESS STEEL 316S11 TO BS 1503 / HASTELLOY C276 TO ASTM-SB575-95
7	OMR.B1.00	OUTER MAGNET SIZE B1 TO SUIT T/LOCK 1210	MILD STEEL (En3B)
7	TLA.1210	TAPER LOCK ADAPTER 1210	070M20 TO BS 970Pt.1
7	TLB.1210/19	TAPER LOCK BUSH 1210 19mm BORE	070M20 TO BS 970Pt.1
7	TLB.1210/24	TAPER LOCK BUSH 1210 24mm BORE	070M20 TO BS 970Pt.1
8	PED.100.00	PEDESTAL 100L/M B1 B2 B3 D90 GPS STD	MILD STEEL (En3B)
9	FKF.100.SS.00	FASTENER KIT 100L/M LOCKNUT, WASHER & KEY	STAINLESS STEEL 316S11 (WASHERS 316S12) TO BS 1503
10.1	SCB.2	BEARING ASSY SILICON CARBIDE SIZE 2 (E3)	SILICON CARBIDE (SILICA FREE)
10.2	CSS.2	O'RING SET 316L FOR SCB SIZE 2	STAINLESS STEEL 316L
10.2	VIT.2	O'RING SET VITON FOR SCB SIZE 2	VITON E-60C
10.2	EPDM.2	O'RING SET EPDM FOR SCB SIZE 2	ETHYLENE PROPYLENE TERPOLYMER
10.2	PTFE.2	O'RING SET PTFE FOR SCB SIZE 2	FEP ENCAPSULATED VITON
10.2	KAL.2	O'RING SET KALREZ FOR SCB SIZE 2	KALREZ 4079 PERFLUOROELASTOMER
11	FLB.1.00	REAR BEARING FLUOROSCINT	FLUOROSCINT

**3.0 DIMENSIONS**

**3.1 Tabulated Drawing**

Pump Model	D1	D2	C
100L	25	25	118
100M	40	25	120

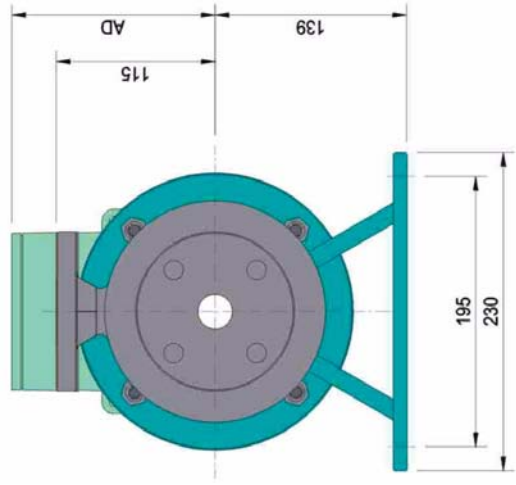
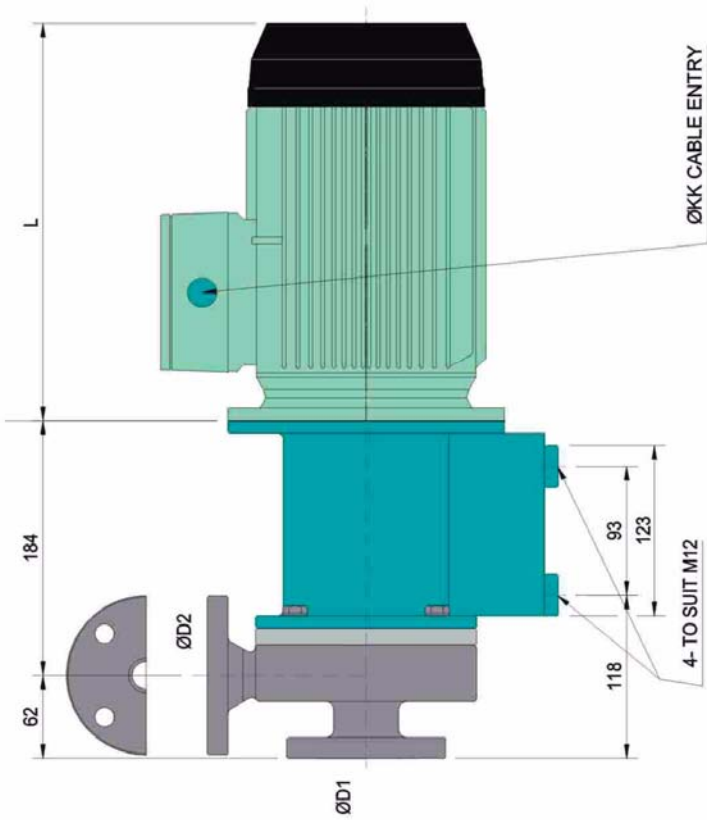

### 3.2 Flange Standards

#### Pump Nomenclature

The pump nomenclature includes the essential information required to identify the pump type and the key elements of its hydraulics: -

Example: - PC 100 L for style 1 (sub-ISO) pumps, PC 50-32-125 for MII (ISO) pumps and HC 160 M for High pressure pumps.

The pump code is formatted as a combination of pump type, branch size (inlet / outlet) and nominal impeller size. It is prefixed with the pump type: -

PC - standard (16 bar) Pump Close coupled, HC High system pressure pump Close coupled.

For ISO pumps the remainder of the code details the inlet or suction bore, followed by the outlet or discharge bore, and lastly, the nominal impeller or pump frame size.

For Style 1 pumps, the remainder of the code details the nominal impeller or pump frame size, followed by a letter L for low flow, M for medium flow and H for high flow. These letters equate as follows: -

L = 25mm suction x 25mm discharge

M = 40mm suction x 25mm discharge

H = 50mm suction x 40mm discharge,

#### Flange Standards

Nominal bore size Metric - Actual	DIN Norm Flanges PN16	Nominal bore size Imperial - Equivalent	ANSI Norm Flanges 150#	ANSI Norm Flanges 300#	ANSI Norm Flanges 600# to 2500#
25mm	25mm	1"	1"	1"	1"
32mm	32mm	1 1/4"	1 1/2"	1 1/2"	1 1/2"
40mm	40mm	1 1/2"	1 1/2"	1 1/2"	1 1/2"
50mm	50mm	2"	2"	2"	2"
65mm	65mm	2 1/2"	2 1/2"	2 1/2"	2 1/2"
80mm	80mm	3"	3"	3"	3"
100mm	100mm	4"	4"	4"	4"
125mm	125mm	5"	5"	5"	5"
150mm	150mm	6"	6"	6"	6"

The pump code reflects the metric sizing. The coding for ANSI flanges is reflected in the more detailed part number (see separate chapter) and not as in ANSI standard pumps: -

e.g. 1515 to denote a 1.5" suction, 1" discharge and 5" nominal impeller.

**Flange machining detail**

For pumps where the flanges are cast into the casing, the following tables outline our machining practice and indicate any deviations from standards.

Whilst it is possible to provide full 300lb flanges, in reality, the pump case is only rated to 16 bar at ambient, and this will become the limiting factor. By including flanges of a higher pressure rating does not mean the pump can be used for higher pressures.

**3.3 Universal Flange Dimensions**

DNC	25mm (1")	32mm (1.1/2")	40mm (1.1/2")	50mm (2")	65mm (2.1/2")
DC	-	140	152	165	185
CC	-	18	19	20	20
FC	-	2	3	3	3
D1C	-	78	92	102	122
DM	115	140	150	165	185
CM	16	17.5	17.5	19	22.2
FM	2	2	2	2	2
D1M	61	78	78	100	118
KM1	79.4	98.4	98.4	120.6	139.7
KM2	85	100	110	125	145
No. Holes	4	4	4	4	4
R			R = 1/2 W		
W	16	18	18	19	19
Notes:					
FLG OD	OK	AS CAST	OK	AS CAST	AS CAST
THK'	OK	OK	OK	OK	AS CAST
R/F OD	OK	AS CAST	OK	OK	OK
HOLE ON					
FLG OD	17.8	20.8	25.8	22.2	22.65

Items suffixed with C for cast dimensions

Items suffixed with M for machined dimensions

Where OD of flange and raised face are as cast dimensions. A full 'clean up' of surfaces is required. Tolerance of OD +/-4.00mm, R/F OD +2.00/-1.00mm.

**Standard Flange Detail**

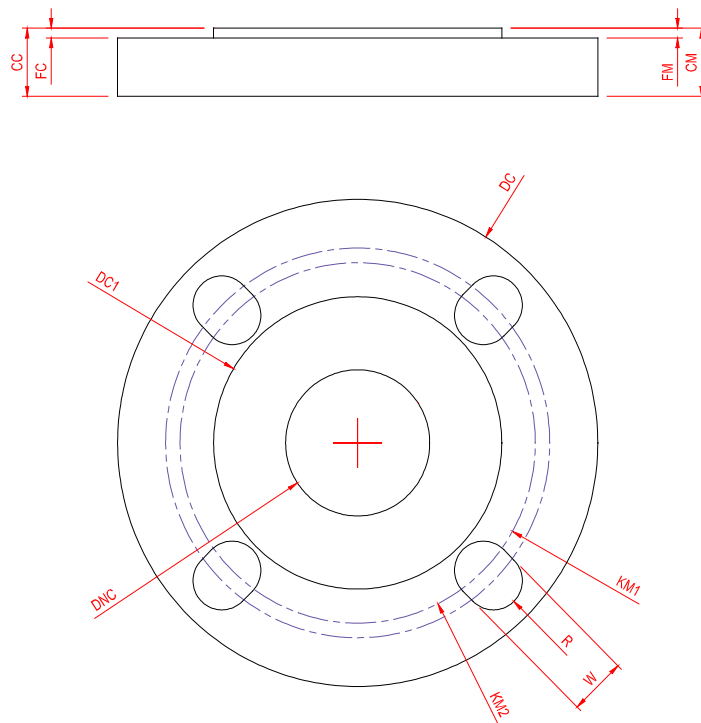

4- HOLE ORIENTATION (upto 65mm/2.1/2")

### 3.4 PN16 Flange Dimensions

DNC	25mm (1")	32mm (1.1/2")	40mm (1.1/2")	50mm (2")	65mm (2.1/2")	80mm (3")	100mm (4")	125mm (5")	150mm (6")
DC	-	140	152	165	185	200	228	254	285
CC	-	18	19	20	20	24	24	26	26
FC	-	2	3	3	3	3	3	3	3
D1C	-	78	92	102	122	138	158	188	212
DM	115	140	150	165	185	200	220	250	285
CM	16	16	16	18	18	20	20	22	22
FM	2	2	3	3	3	3	3	3	3
D1M	68	78	88	102	122	138	158	188	212
KM	85	100	110	125	145	160	180	210	240
No. Holes	4	4	4	4	4	8	8	8	8
Dia. Holes	14	18	18	18	18	18	18	18	18

Notes:

FLG OD	OK	AS CAST	OK	AS CAST	AS CAST	AS CAST	OK	OK	AS CAST
THK'	OK	OK	OK	OK	OK	OK	OK	OK	OK
R/F OD	OK	AS CAST	OK	AS CAST	AS CAST	AS CAST	AS CAST	AS CAST	AS CAST
HOLE ON									
FLG OD	8	11	11	11	11	11	11	11	13.5

Items suffixed with C for cast dimensions

Items suffixed with M for machined dimensions

Where OD of flange and raised face are as cast dimensions. A full 'clean up' of surfaces is required. Tolerance of OD +/-4.00mm, R/F OD +2.00/-1

#### General flange detail

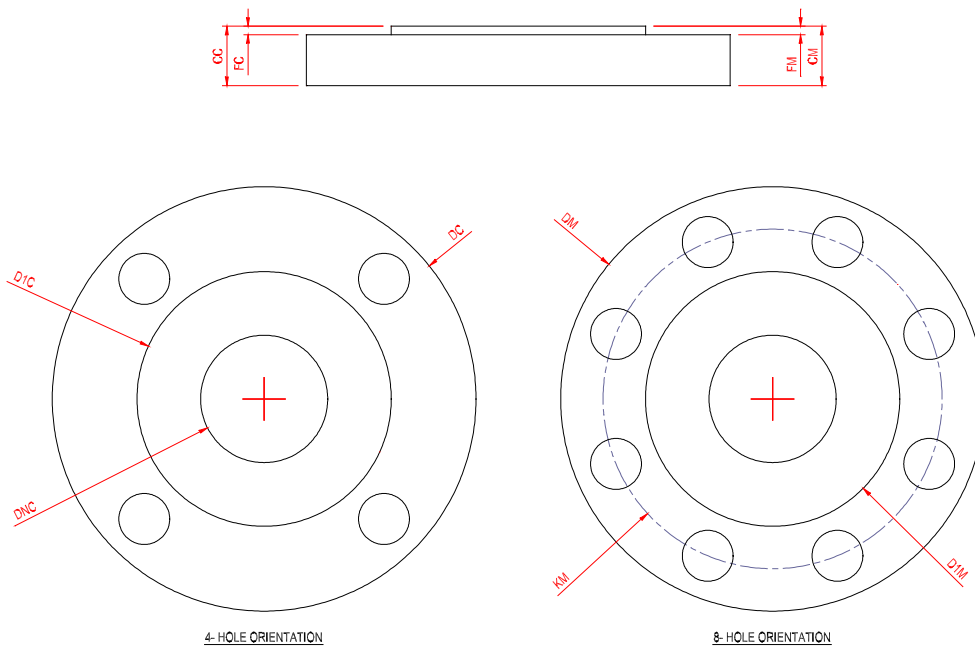

### 3.5 ANSI.150 Flange Dimensions

DNC	25mm (1")	32mm (1.1/2")	40mm (1.1/2")	50mm (2")	65mm (2.1/2")	80mm (3")	100mm (4")	125mm (5")	150mm (6")
DC	-	140	152	165	185	200	228	254	285
CC	-	18	19	20	20	24	24	26	26
FC	-	2	3	3	3	3	3	3	3
D1C	-	78	92	102	122	138	158	188	212
DM	108	127	127	152	178	190	229	254	279
CM	14.3	17.5	17.5	19	22.2	23.8	23.8	23.8	25.4
FM	1.6	1.6	1.6	1.6	1.6	1.6	1.6	1.6	1.6
D1M	50.8	73	73	92.1	104.8	127	157.2	185.7	215.9
KM	79.4	98.4	98.4	120.6	139.7	152.4	190.5	215.9	241.3
No. Holes	4	4	4	4	4	4	8	8	8
Dia. Holes	15.9	15.9	15.9	19	19	19	19	22.2	22.2
Notes:									
FLG OD	OK	OK	OK	OK	OK	OK	AS CAST	AS CAST	OK
THK'	OK	OK	OK	OK	AS CAST	OK	OK	OK	OK
R/F OD	OK	OK	OK	OK	OK	OK	OK	OK	OK
HOLE ON									
FLG OD	6.35	6.35	6.35	6.2	9.65	9.3	9.75	7.95	7.75

Items suffixed with C for cast dimensions

Items suffixed with M for machined dimensions

Where OD of flange and raised face are as cast dimensions. A full 'clean up' of surfaces is required. Tolerance of OD +/-4.00mm, R/F OD +/-0.8mm.

### 3.6 ANSI.300 Flange Dimensions

DNC	25mm (1")	32mm (1.1/2")	40mm (1.1/2")	50mm (2")	65mm (2.1/2")	80mm (3")	100mm (4")	125mm (5")	150mm (6")
DC	-	-	-	-	-	-	-	-	-
CC	-	-	-	-	-	-	-	-	-
FC	-	-	-	-	-	-	-	-	-
D1C	-	-	-	-	-	-	-	-	-
DM	124	156	156	165	190	210	254	279	318
CM	17.5	20.6	20.6	22.2	25.4	28.6	31.8	34.9	36.5
FM	1.6	1.6	1.6	1.6	1.6	1.6	1.6	1.6	1.6
D1M	50.8	73	73	92.1	104.8	127	157.2	185.7	215.9
KM	88.9	114.3	114.3	127	149.2	168.3	200	235	269.9
No. Holes	4	4	4	8	8	8	8	8	12
Dia. Holes	19	22.2	22.2	19	22.2	22.2	22.2	22.2	22.2
Notes:									
FLG OD	OK	OK	OK	OK	OK	OK	OK	OK	OK
THK'	OK	OK	OK	OK	OK	OK	OK	OK	OK
R/F OD	OK	OK	OK	OK	OK	OK	OK	OK	OK
HOLE ON									
FLG OD	8.05	9.75	9.75	9.5	9.3	9.75	15.9	10.9	12.95

Items suffixed with C for cast dimensions

Items suffixed with M for machined dimensions

Where OD of flange and raised face are as cast dimensions. A full 'clean up' of surfaces is required. Tolerance of OD +/-4.00mm, R/F OD +/-0.8mm.

Flange sizes detailed without cast dimensions to be fitted with pre-machined flanges.